

SPRINT CAR COMPONENTS

Steering Arms



All Wintes sprint steering arms are forged 7075-T6 aluminum

1	2	3	4	5	P/N
5.737"	.981"	6.00"	.598"	3.25"	WIN 3452
5.737"	.981"	N/A	N/A	3.25"	WIN 3451
5 1/2"	.625"	N/A	N/A	3.25"	WIN 3651
5 1/2"	.625"	6.375"	.500"	3.25"	WIN 3652

- 1- Dimension from tie rod center line to king pin
- 2- Dimension from tie rod center line to spindle
- 3- Dimension from drag link center line to spindle
- 4- Dimension from drag link center line to king pin center line
- 5- Dimension from mounting bolt to mounting bolt

Aluminum Front Spindle

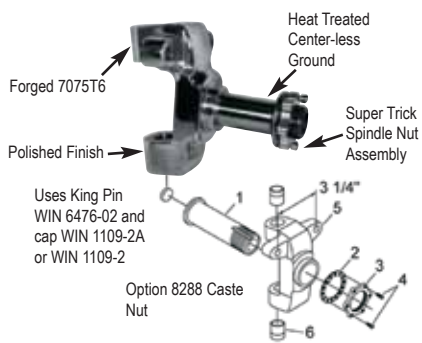

Uses King Pin WIN 6476-02 and cap WIN 1109-2A or WIN 1109-2

Option 8288 Cast Nut

DESCRIPTION	P/N
Sprint 10° Front Spindle Kit	WIN 3622
Sprint 10° Front Spindle Kit with Titanium Shaft	WIN 3622T

DESCRIPTION	#	QTY	P/N
Spindle Shaft	1	1	WIN 3459
Titanium Shaft	1	1	WIN 3459T
Lockwasher	2	1	WIN 2124
Locknut	3	1	WIN 2125
Cap Screw	4	2	WIN 2126
Spindle Base	5	1	WIN 3458
Bushing	6	2	WIN 7515
Core Plug	7	1	WIN 7860

Aluminum Front Hub Kits

Hub P/N WIN 3783-01 with alum. rotor mount w. studs and races

Hub P/N WIN 3783 w. studs and races



DESCRIPTION	QTY	P/N
Right Hub	1	WIN 3783
Left Hub with rotor mount	1	WIN 3783-01
Single Lip Seal (grease)	2	WIN 7297V
Double Lip Seal (oil)	2	WIN 7291V
Inner Bearing Cone	2	WIN 8666
Inner Bearing Cup	2	WIN 8635
Bolt	10	WIN 8731
Nut	10	WIN 8735
O-Ring	2	WIN 8419
Screw In Hb Cap	2	WIN 3749-01
Shim (must use WIN 7291V)	2	WIN 3748

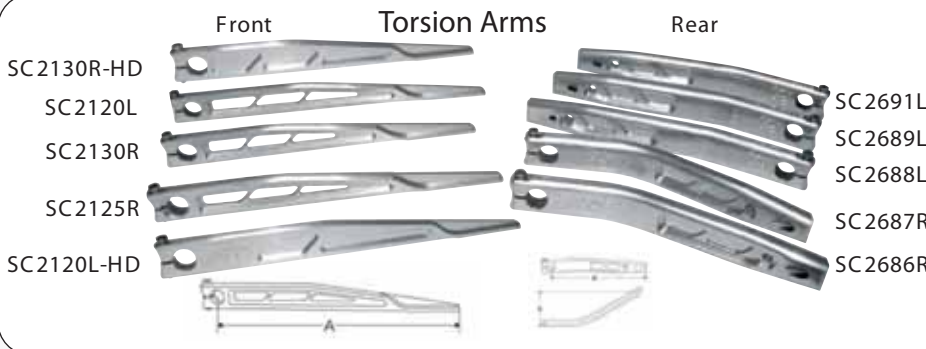
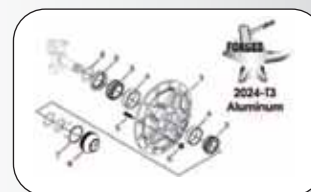

A	ANGLE	P/N	A	B	P/N
18 1/2"		WIN SC2120L	13 1/4"	4 1/2"	WIN SC2686R
18 1/2"		WIN SC2120L-HD	13 1/4"	5 1/4"	WIN SC2687R
16 3/4"	10°	WIN 2125R	15"	2 1/2"	WIN SC2688L
16 3/4"		WIN 2130R	15"	3"	WIN SC2689L
			15"	3 1/4"	WIN SC2691L

- Heavy Duty Styles are for racers that "feel" the arms flex under load
- 10° Angle broach makes wheel rate stiffer
- Contact patch under the arm is rounded to prevent premature wear

- Winters rear arms are solid from the bend to the back of the rear arm to help reduce flexing. Winters is the only one to offer this feature
- Winters rear arms are the only ones to offer a light press fit on the shock bolt mounting area.
- Most popular right rear arm is WIN SC2687R
- Most popular left rear arm is WIN SC2691L
- 100% machined surface

Pitman Arms

- Broach "Straight" or Standard Arms
- 10° Broach Arms for shorter steering arm shaft, or for more header clearance
- Lightweight arms offer more protection for steering box
- The most popular style WIN SC2260
- 100% Machined

BROACH	A	B	P/N
Straight	11"		WIN SC2230
Straight	11"	12"	WIN SC2240
10° Angle	11"		WIN SC2250
10° Angle	11"	12"	WIN SC2260
Straight	11"		WIN SC2270
Straight	11"	12"	WIN SC2280
10° Angle	11"		WIN SC2290
10° Angle	11"	12"	WIN SC2300

