

## 1 7/8" I.D. AFco COIL SPRINGS

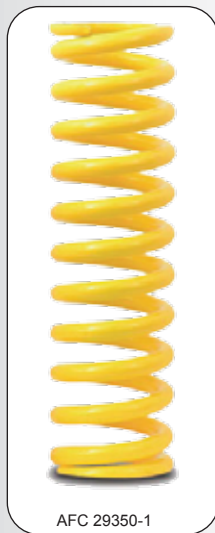

AFC 29350-1

### 1 7/8" Diameter X 10" Long

| RATE | P/N         | RATE | P/N         |
|------|-------------|------|-------------|
| 50   | AFC 29050-1 | 275  | AFC 29275-1 |
| 60   | AFC 29060-1 | 300  | AFC 29300-1 |
| 75   | AFC 29075-1 | 325  | AFC 29325-1 |
| 90   | AFC 29090-1 | 350  | AFC 29350-1 |
| 105  | AFC 29105-1 | 375  | AFC 29375-1 |
| 120  | AFC 29120-1 | 400  | AFC 29400-1 |
| 135  | AFC 29135-1 | 425  | AFC 29425-1 |
| 150  | AFC 29150-1 | 450  | AFC 29450-1 |
| 175  | AFC 29175-1 | 475  | AFC 29475-1 |
| 200  | AFC 29200-1 | 500  | AFC 29500-1 |
| 225  | AFC 29225-1 | 525  | AFC 29525-1 |
| 250  | AFC 29250-1 | 550  | AFC 29550-1 |

## CONVENTIONAL SPRINGS

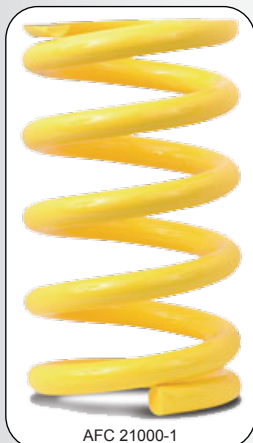

AFC 21000-1

### 5 1/2" Diameter X 9 1/2" Long Front Springs For Cars Using Wedge Bolts

| RATE | P/N         | RATE | P/N         |
|------|-------------|------|-------------|
| 500  | AFC 20500-1 | 950  | AFC 20950-1 |
| 550  | AFC 20550-1 | 1000 | AFC 21000-1 |
| 600  | AFC 20600-1 | 1050 | AFC 21050-1 |
| 650  | AFC 20650-1 | 1100 | AFC 21100-1 |
| 700  | AFC 20700-1 | 1150 | AFC 21150-1 |
| 750  | AFC 20750-1 | 1200 | AFC 21200-1 |
| 800  | AFC 20800-1 | 1300 | AFC 21300-1 |
| 850  | AFC 20850-1 | 1400 | AFC 21400-1 |
| 900  | AFC 20900-1 |      |             |

## STREET STOCK SPRINGS

### For Cars NOT Using Wedge Bolts

**Did You Know...**  
Street stock springs are painted black to conform to most "stock appearing" rules.



AFC 21000-6

### 5 1/2" X 11" Front Metric Springs

| RATE | P/N         |
|------|-------------|
| 600  | AFC 20600-6 |
| 700  | AFC 20700-6 |
| 800  | AFC 20800-6 |
| 900  | AFC 20900-6 |
| 1000 | AFC 21000-6 |
| 1100 | AFC 21100-6 |
| 1200 | AFC 21200-6 |
| 1300 | AFC 21300-6 |
| 1400 | AFC 21400-6 |



AFC 25225SS

### 5 1/2" X 12" Pigtail Metric Rear Springs

| RATE | P/N         |
|------|-------------|
| 150  | AFC 25150SS |
| 175  | AFC 25175SS |
| 200  | AFC 25200SS |
| 225  | AFC 25225SS |
| 250  | AFC 25250SS |
| 275  | AFC 25275SS |
| 300  | AFC 25300SS |



PCR 310-5512-1100

### 5 1/2" X 12" Camaro Front Springs

| RATE | P/N               |
|------|-------------------|
| 600  | PCR 310-5512-600  |
| 700  | PCR 310-5512-700  |
| 800  | PCR 310-5512-800  |
| 900  | PCR 310-5512-900  |
| 1000 | PCR 310-5512-1000 |
| 1100 | PCR 310-5512-1100 |
| 1200 | PCR 310-5512-1200 |
| 1300 | PCR 310-5512-1300 |
| 1400 | PCR 310-5512-1400 |

# SPRINGS & ACCESSORIES

## 2 1/2" I.D. INTEGRA MX SPRINGS



**NEW PRODUCT**

Did You Know...

### The Integra MX Advantage

Integra uses an exclusive VMX alloy not found in any other racing springs. This allows Integra MX springs to be manufactured up to 30% lighter and have up to 30% more stroke, yielding up to 1 1/4" more travel before coil bind than other springs. This gives you a lighter, more linear spring with added travel before coil bind.

### 2 1/2" Diameter X 12" Long

| RATE | P/N                |
|------|--------------------|
| 150  | PCR 310-2512-150MX |
| 175  | PCR 310-2512-175MX |
| 200  | PCR 310-2512-200MX |
| 225  | PCR 310-2512-225MX |
| 250  | PCR 310-2512-250MX |
| 275  | PCR 310-2512-275MX |
| 300  | PCR 310-2512-300MX |
| 325  | PCR 310-2512-325MX |
| 350  | PCR 310-2512-350MX |
| 375  | PCR 310-2512-375MX |
| 400  | PCR 310-2512-400MX |

## 2 1/2" I.D. AFCO SPRINGS

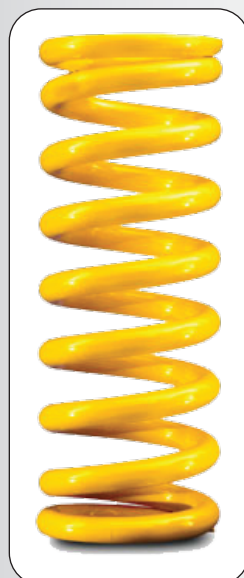

### 2 1/2" I.D. X 10" Long

| RATE | P/N       |
|------|-----------|
| 100  | AFC 23100 |
| 125  | AFC 23125 |
| 150  | AFC 23150 |
| 175  | AFC 23175 |
| 200  | AFC 23200 |
| 225  | AFC 23225 |
| 250  | AFC 23250 |
| 275  | AFC 23275 |
| 300  | AFC 23300 |
| 325  | AFC 23325 |
| 350  | AFC 23350 |
| 375  | AFC 23375 |
| 400  | AFC 23400 |
| 425  | AFC 23425 |
| 450  | AFC 23450 |
| 475  | AFC 23475 |
| 500  | AFC 23500 |
| 525  | AFC 23525 |
| 550  | AFC 23550 |
| 575  | AFC 23575 |
| 600  | AFC 23600 |
| 650  | AFC 23650 |

### 2 1/2" I.D. X 12" Long

| RATE | P/N       |
|------|-----------|
| 80   | AFC 22080 |
| 100  | AFC 22100 |
| 125  | AFC 22125 |
| 150  | AFC 22150 |
| 160  | AFC 22160 |
| 175  | AFC 22175 |
| 185  | AFC 22185 |
| 200  | AFC 22200 |
| 225  | AFC 22225 |
| 250  | AFC 22250 |
| 275  | AFC 22275 |
| 300  | AFC 22300 |
| 325  | AFC 22325 |
| 350  | AFC 22350 |
| 375  | AFC 22375 |
| 400  | AFC 22400 |
| 425  | AFC 22425 |
| 450  | AFC 22450 |
| 475  | AFC 22475 |
| 500  | AFC 22500 |
| 525  | AFC 22525 |
| 550  | AFC 22550 |
| 575  | AFC 22575 |
| 600  | AFC 22600 |
| 650  | AFC 22650 |
| 700  | AFC 22700 |
| 750  | AFC 22750 |
| 800  | AFC 22800 |
| 850  | AFC 22850 |

### 2 1/2" I.D. X 14" Long

| RATE | P/N       |
|------|-----------|
| 80   | AFC 24080 |
| 100  | AFC 24100 |
| 110  | AFC 24110 |
| 125  | AFC 24125 |
| 150  | AFC 24150 |
| 160  | AFC 24160 |
| 175  | AFC 24175 |
| 185  | AFC 24185 |
| 200  | AFC 24200 |
| 225  | AFC 24225 |
| 250  | AFC 24250 |
| 275  | AFC 24275 |
| 300  | AFC 24300 |
| 325  | AFC 24325 |
| 350  | AFC 24350 |

## 2 1/2" I.D. HYPERCO SPRINGS



**HYPERCO**

### 2 1/2" I.D. X 10" Long

| RATE | P/N         |
|------|-------------|
| 150  | HYP 10BO150 |
| 175  | HYP 10BO175 |
| 200  | HYP 10BO200 |
| 225  | HYP 10BO225 |
| 250  | HYP 10BO250 |
| 275  | HYP 10BO275 |
| 300  | HYP 10BO300 |

### 2 1/2" I.D. X 12" Long

| RATE | P/N         |
|------|-------------|
| 150  | HYP 12BO150 |
| 175  | HYP 12BO175 |
| 200  | HYP 12BO200 |
| 225  | HYP 12BO225 |
| 250  | HYP 12BO250 |
| 275  | HYP 12BO275 |
| 300  | HYP 12BO300 |

### 2 1/2" I.D. X 14" Long

| RATE | P/N         |
|------|-------------|
| 150  | HYP 14BO150 |
| 175  | HYP 14BO175 |
| 200  | HYP 14BO200 |
| 225  | HYP 14BO225 |
| 250  | HYP 14BO250 |
| 275  | HYP 14BO275 |
| 300  | HYP 14BO300 |

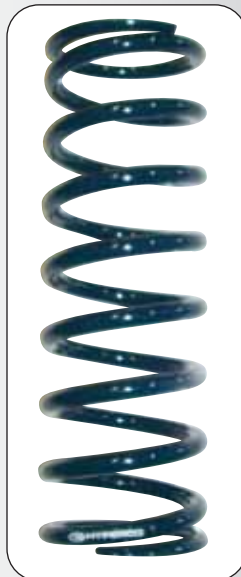

## 2 1/2" I.D. EIBACH SPRINGS



### 2 1/2" I.D. X 10" Long

| RATE | P/N               |
|------|-------------------|
| 150  | EIB 1000.250.0150 |
| 175  | EIB 1000.250.0175 |
| 200  | EIB 1000.250.0200 |
| 225  | EIB 1000.250.0225 |
| 250  | EIB 1000.250.0250 |
| 275  | EIB 1000.250.0275 |
| 300  | EIB 1000.250.0300 |

### 2 1/2" I.D. X 12" Long

| RATE | P/N               |
|------|-------------------|
| 80   | EIB 1200.250.0080 |
| 100  | EIB 1200.250.0100 |
| 125  | EIB 1200.250.0125 |
| 150  | EIB 1200.250.0150 |
| 165  | EIB 1200.250.0165 |
| 175  | EIB 1200.250.0175 |
| 185  | EIB 1200.250.0185 |
| 200  | EIB 1200.250.0200 |
| 225  | EIB 1200.250.0225 |
| 250  | EIB 1200.250.0250 |
| 275  | EIB 1200.250.0275 |
| 300  | EIB 1200.250.0300 |

### 2 1/2" I.D. X 8" Long

| RATE | P/N               |
|------|-------------------|
| 425  | EIB 0800.250.0425 |
| 450  | EIB 0800.250.0450 |
| 475  | EIB 0800.250.0475 |
| 500  | EIB 0800.250.0500 |
| 525  | EIB 0800.250.0525 |

### 2 1/2" I.D. X 14" Long

| RATE | P/N               |
|------|-------------------|
| 125  | EIB 1400.250.0125 |
| 150  | EIB 1400.250.0150 |
| 175  | EIB 1400.250.0175 |
| 200  | EIB 1400.250.0200 |
| 225  | EIB 1400.250.0225 |
| 250  | EIB 1400.250.0250 |
| 275  | EIB 1400.250.0275 |
| 300  | EIB 1400.250.0300 |



## 2 1/2" I.D. INTEGRA BARREL SPRINGS



### 2 1/2" I.D. X 13" Long

| RATE | P/N               |
|------|-------------------|
| 150  | PCR 310-2513-150B |
| 160  | PCR 310-2513-160B |
| 175  | PCR 310-2513-175B |
| 185  | PCR 310-2513-185B |
| 200  | PCR 310-2513-200B |
| 225  | PCR 310-2513-225B |
| 250  | PCR 310-2513-250B |
| 275  | PCR 310-2513-275B |
| 300  | PCR 310-2513-300B |

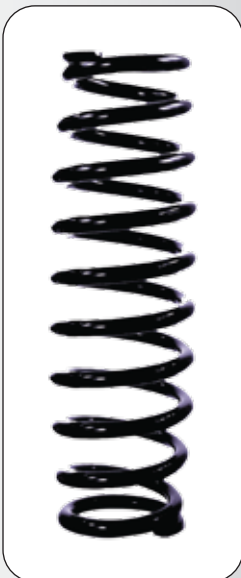

## TAKE UP SPRINGS



| DESCRIPTION                                  | P/N              |
|--|------------------|
| Integra Take Up Spring (black powder coated) | PCR 310-3006-005 |
| Nylon Slider                                 | PCR 310-30400    |
| Aluminum Slider                              | BRP 597          |

## MULTI-LEAF SPRINGS

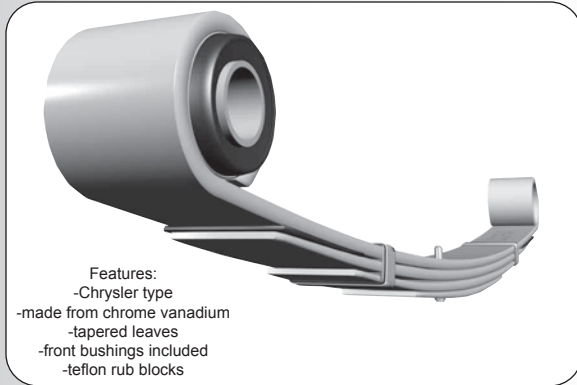

| DESCRIPTION              | CAR WEIGHT | SPRING RATE | P/N          |
|--------------------------|------------|-------------|--------------|
| 5" Arch Standard Cars    | 2400-2800# | 142#        | AFC 20231    |
| 5" Arch Lightweight Cars | 2000-2400# | 102#        | AFC 20231L   |
| 5" Arch Medium Cars      | 2600-3000# | 152#        | AFC 20231MHD |
| 5" Arch Heavy Cars       | 2800-3200# | 166#        | AFC 20231HD  |
| 5" Arch Extra Heavy Cars | 3100-3500# | 194#        | AFC 20231XHD |

## LEAF SPRING ACCESSORIES



| DESCRIPTION   | P/N          |
|---|--------------|
| Steel Leaf Spring Pivot Bushing                               | BRP 5174     |
| Steel Leaf Spring Slider                                      | AFC 20236S   |
| Replacement Bearing for AFC 20236S Leaf Spring Slider         | AFC 20236S-2 |
| Aluminum Shackle Plate (2 required)                           | BRP 5169     |
| Steel 2 1/2" Leaf Spring Mounting Pad (works on 3" axle tube) | AFC 20232    |
| Leaf Spring Slider (used on most leaf spring cars)            | AFC 20236    |
| 3" Clamp on Pad for 2 1/2" Leaf Springs                       | ALL 56127    |
| Leaf Spring Shackle Bolt Kit                                  | BRP 5170     |
| Replacement Shoulder Bolt for BRP 5170                        | BRP 5171     |
| Replacement Bushing for BRP 5170                              | BRP 5172     |
| 8" U-Bolt for 3" Tubes (comes with nuts)                      | AFC 20238    |
| 9 1/2" U-Bolt for 3" Tubes (comes with nuts)                  | AFC 20238-9  |
| 1 1/2" Adjustable Lowering Block                              | BRP 6160     |
| 2 1/2" Adjustable Lowering Block                              | BRP 6162     |

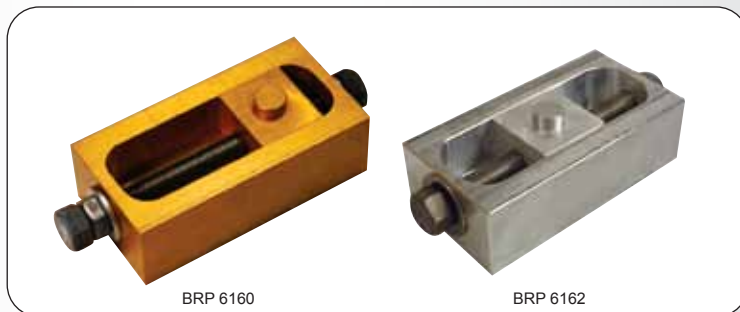

## WEIGHT JACK ASSEMBLIES

### Did You Know...

These weight jack assemblies use 1 1/8" F jack bolts and are used for 5" and 5 1/2" springs.



BRP 6135

BRP 6155

### Standard Weight Jack Assemblies

| SPRING DIAMETER   | LENGTH | SEAT     | BOLT     | P/N      |
|-------------------|--------|----------|----------|----------|
| 5" Spring         | 6"     | STEEL    | STEEL    | BRP 6148 |
| 5 1/2" Spring     | 6"     | STEEL    | STEEL    | BRP 6150 |
| 5" Spring         | 8"     | STEEL    | STEEL    | BRP 6152 |
| 5 1/2" Spring     | 8"     | STEEL    | STEEL    | BRP 6154 |
| 5" Spring         | 8"     | STEEL    | ALUMINUM | BRP 6151 |
| 5 & 5 1/2" Spring | 6"     | ALUMINUM | ALUMINUM | BRP 6155 |
| 5 & 5 1/2" Spring | 8"     | ALUMINUM | ALUMINUM | BRP 6156 |

### Replacement Weight Jack Parts

| DESCRIPTION                       | P/N        |
|-----------------------------------|------------|
| 4" Aluminum Wedge Bolt - 1 1/8" F | BRP 6135   |
| 6" Aluminum Wedge Bolt - 1 1/8" F | BRP 6136   |
| 8" Aluminum Wedge Bolt - 1 1/8" F | BRP 6137   |
| 6" Steel Wedge Bolt - 1 1/8" F    | BRP 6145   |
| 8" Steel Wedge Bolt - 1 1/8" F    | BRP 6146   |
| 1 1/8" F Thread Nut               | BRP 5150   |
| 5" Steel Spring Seat              | BRP 6143   |
| 5 1/2" Steel Spring Seat          | BRP 6144   |
| 5 & 5 1/2" Aluminum Spring Seat   | AFC 20197R |

## CONVENTIONAL WEIGHT JACK ASSEMBLIES

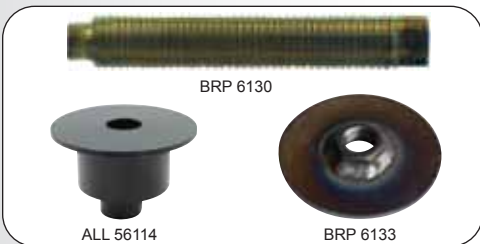

BRP 6130

ALL 56114

BRP 6133

### Did You Know...

These weight jacks are made for conventional spring type cars using 1" C weight jack bolts.

| DESCRIPTION                      | P/N       |
|----------------------------------|-----------|
| 1" C X 8" Long Steel Wedge Bolt  | BRP 6130  |
| 1" C X 11" Long Steel Wedge Bolt | BRP 6131  |
| Weld on Adjuster Plate           | BRP 6133  |
| Spring Cup                       | ALL 56114 |

## COIL SPRING ADJUSTERS & SPACERS



ALL 56116

| DESCRIPTION  | P/N       |
|--|-----------|
| 5" or 5 1/2" Coil Spring Spacer (I.D. open for stock mount racing) | ALL 56116 |



BRP 5151

| DESCRIPTION   | P/N       |
|---|-----------|
| 5" or 5 1/2" Coil Spring Adjustable Spring Spacer (has 2" travel) | BRP 5151  |
| Replacement Nut   | BRP 5151B |



BRP 5157

| DESCRIPTION   | P/N      |
|---|----------|
| 5" or 5 1/2" Coil Spring Bucket (works with any 1 1/8" F jack bolt) | BRP 5157 |



BRP 5156

| DESCRIPTION   | P/N      |
|---|----------|
| Rear Spring Seat (mounts 5 or 5 1/2" springs on rear axle tube) | BRP 5156 |