

FRONT SPINDLES, HUBS & ACCESSORIES

FORD 10 DEGREE ALUMINUM STUBBY SPINDLE

Ford 10 Degree Aluminum Stubby .859" King Pin Diameter

SPINDLE
BRP4582

4.60 lbs

NEW PRODUCT

Comes complete with hollow king pin, caps, locking nut, and shim

- Designed for the BRP4570 lifetime warranty hub.
- 7075 billet aluminum body with steel snout for ultimate durability.
- Weighs just 4 pounds (less kingpin).
- King pin bores have replaceable bronze bushings.
- Spindle snout is threaded into body for high strength while reverse thread locknut keeps the spindle snout tight under racing conditions.



FORD KING PIN DRIFT
BRP847



BRP841



BRP842



SNOUT WRENCH
BRP4584

DESCRIPTION	P/N
Aluminum spindle kit with gun drilled steel king pin, steel spindle snout, and locking nut	BRP4582
Replacement snout and inner lock cap	BRP4580
Snout wrench	BRP4584
Replacement king pin with 2 end caps	BRP841
Replacement king pin cap (sold each)	BRP841C
(Optional titanium king pin)	BRP841T
Replacement cap for titanium king pin (sold each)	BRP841TC
Ford king pin bushings (sold each)	BRP842
1/8" Aluminum spindle shim spacer	BRP843
Locking nut kit (sold each)	BRP831L
Wrench for BRP831	BRP831W
Steel spindle nut (use with BRP830 tab washer)	BRP831
Locking tab washer (use with BRP831 and 831A)	BRP830

BRP WIDE 5 CONVERSION HUBS TO FORD SPINDLE

NEW PRODUCT

LIFETIME WARRANTY
(less races, cap and studs)

- LIFETIME WARRANTY against bending, cracking, and other failures caused by racing. (Warranty limited to original owner, and must have original receipt.)



Uses BRP65 or BRP65W Brake Rotor

BRP4570

- Wider bearing stance for greater stability.
- Less rotor deflection.
- Made from forged aluminum, which is stronger than a machined billet.
- Quick turn dust cap - makes installing/ uninstalling a snap!
- Weighs only 7.0 pounds including studs, races, and dust cap.
- Saves weight over 6 pin - wheel adaptor set-up
- Comes with BRP4571 dust cap, studs and races
- Same parts as 6 pin hub

When mounting a BRP4570 hub & 11" rotor to a BRP4582 spindle, use a BRP8-2250 brake bracket for a Dynalite II caliper and a BRP18-2375 brake bracket for a Dynalite single caliper.

Inner & outer bearings, grease seal, wheel nuts sold separately

DESCRIPTION	P/N
Inner race	BRP826
Outer race	BRP827
Inner bearing	BRP828
Outer bearing	BRP829
Aluminum locking spindle nut assembly	BRP831L
Inner hub seal	BRP835
Dust cap	BRP4571
Rotor bolt	BOL081003F

Wider bearing stance than the BRP4590 and BRP821 combination by 1/2" but doesn't affect wheel offset.

FRONT SPINDLES, HUBS & ACCESSORIES

FORD 10 DEGREE ALUMINUM STUBBY SPINDLE

Ford 10 Degree Aluminum Stubby .859" King Pin Diameter

SPINDLE
BRP4590

4.60 lbs

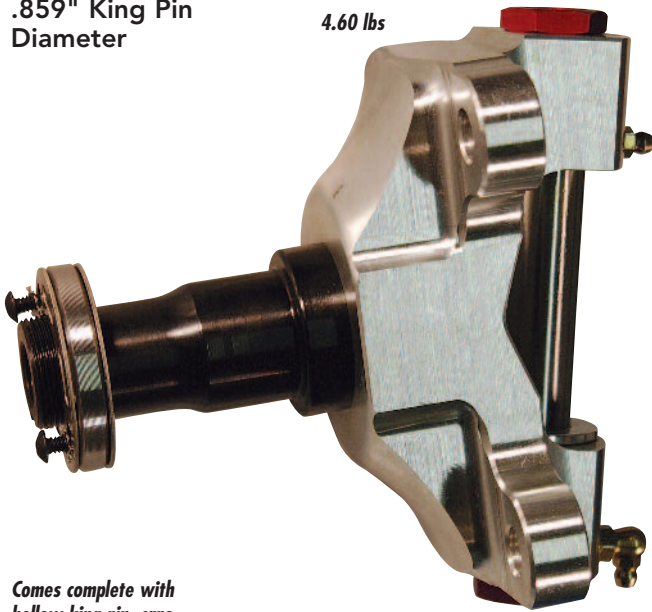

Comes complete with hollow king pin, caps, locking nut, and shim

DESCRIPTION	P/N
Aluminum spindle kit with gun drilled steel king pin, steel spindle snout, and locking nut	BRP4590
Replacement snout and inner lock cap	BRP4594
Snout wrench	BRP4584
Replacement king pin with 2 end caps	BRP841
Replacement king pin cap (sold each)	BRP841C
(Optional titanium king pin)	BRP841T
Replacement cap for titanium king pin (sold each)	BRP841TC
Ford king pin bushings (sold each)	BRP842
1/8" Aluminum spindle shim spacer	BRP843
Locking nut kit (sold each)	BRP831L
Wrench for BRP831	BRP831W
Steel spindle nut (use with BRP830 tab washer)	BRP831
Locking tab washer (use with BRP831 and 831A)	BRP830



BRP841



BRP842



FORD KING PIN DRIFT
BRP847

SNOUT WRENCH
BRP4584



BRP WIDE 5 CONVERSION HUBS TO FORD SPINDLE

Uses BRP65 or BRP65W Brake Rotor



BRP821

- Machined from forged aluminum
- Saves weight over 6 pin - wheel adaptor set-up
- Comes with BRP832 dust cap, studs and races
- Same parts as 6 pin hub

When mounting a BRP821 hub & 11" rotor to a BRP4590 spindle, use a BRP8-2250 brake bracket for a Dynalite II caliper and a BRP18-2375 brake bracket for a Dynalite single caliper.

Inner & outer bearings, grease seal, wheel nuts sold separately

DESCRIPTION	P/N
Inner race	BRP826
Outer race	BRP827
Inner bearing	BRP828
Outer bearing	BRP829
Aluminum locking spindle nut assembly	BRP831L
Inner hub seal	BRP835
Dust cap	BRP832
Rotor bolt	BOL081003F

FRONT SPINDLES, HUBS & ACCESSORIES

ALUMINUM 6 PIN FRONT HUBS

Modified 6 pin Hub Kit

1" Deep
Hub Face



KIT
BRP824-1

Kit includes: **BRP825-1, BRP828, BRP829, BRP832, BRP835, (3) BRP836.**

Hub includes Rotor Stands and Bolts

Sprint Car Hub Kit

1-1/2" Deep
Hub Face



KIT
BRP824

Kit Includes: **BRP825, BRP828, BRP829, BRP832, BRP835, (3) BRP836**

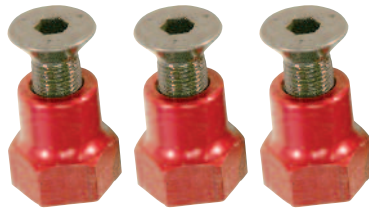

Aluminum Rotor Stands & Bolts

1-3/16" ROTOR STANDS (RED)
Set of 3 **BRP837**

1-5/8" ROTOR STANDS (BLACK)
Set of 3 **BRP838**
Replacement Bolt (sold each) **BOL081003F**

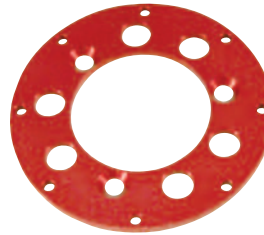

ROTOR ADAPTER FOR 12" ROTOR - 8 ON 7
BRP813

(use with BRP18-1 caliper brackets)



INNER SEAL
BRP835



WRENCH FOR LOCKING (BRP831L) SPINDLE NUT
BRP831W

REPLACEMENT 6 PIN STUD
BRP833

JAM NUT FOR STUD
BRP834



LOCKING NUT ASSEMBLY
BRP831L

SLOTTED WASHER ONLY
BRP831L2



ALUMINUM 6 PIN WHEEL NUTS
BRP836

DESCRIPTION	P/N
Standard sprint hub with studs and races	BRP825
Offset modified hub with studs and races	BRP825-1
Inner race	BRP826
Outer race	BRP827
Inner bearing	BRP828
Outer bearing	BRP829
Steel spindle nut*	BRP830
Aluminum locking spindle nut assembly	BRP831L
Slotted washer only	BRP831L2

* Requires BRP830 Tab Washer

DESCRIPTION	P/N
Wrench for BRP831L spindle nut	BRP831W
Dust cap with O-ring	BRP832
Replacement O-ring for dust cap	BRP832S
5/8" C Wheel stud	BRP833
Titanium wheel stud 5/8" C	BRP833T
Jam nut for BRP833 wheel stud	BRP834
Inner hub seal	BRP835
5/8" C flat ended aluminum wheel nut (red)	BRP836
Rotor stand kit for BRP825 hub (red)	BRP837
Long rotor stand kit for BRP825-1 hub (black)	BRP838
Rotor bolt 1/2" x 1" flat head	BOL081003F

FRONT SPINDLES, HUBS & ACCESSORIES

LARGE BEARING MODIFIED SPINDLE PARTS



Front Spindle & Parts

Spindle Includes (1) BRP841, (2) BRP841C, (2) BRP842	BRP4588
Kingpin	BRP841
Kingpin caps (sold each)	BRP841C
Kingpin bushing	BRP842
Bolt Kit	BRP4588B



BRP6221 BERCTD-NYM-H01 WIN3266F

Front Hubs

Magnesium Front Hub	BRP6221
Aluminum Front Hub	BERCTD-NYM-H01
Aluminum Front Hub	WIN3266F



Snap Ring (inner seal)

BRP6223

Steel Spindle Nut Only

BRP6229



Hub Bearing (inner and outer)

BRP6224



Locking Spindle Nut Assembly

BRP6230



Bearing Race

BRP6222



Hub Seal

BRP6225



Spindle Dust Cover

BRP6226 (Comes with 5 bolts)
WIN3289 (Bolts not included)



Adjuster Nut Wrench

BRP6231

WIDE 5 HUBS



WILWOOD Starlight "55" Wide 5 Racing Hubs

Front Hubs
Starlite "55" Snap-Cap
Front Hub with Hubcap,
Standard Studs.

WIL270-6735C



WILWOOD Aluminum Hub

Standard aluminum
wide 5 hub
8 on 7" rotor bolt
pattern
5/8" coarse studs

WIL270-1956C



WINTERS Aluminum Hub

Standard aluminum
wide 5 hub
8 on 7" rotor bolt
pattern
5/8" coarse studs

WIN6690



Aluminum Dust Cover

RED ANODIZED
BRP119A

INTERNATIONAL STEEL SPINDLE

COMES WITH EVERYTHING SHOWN.

BRP1664

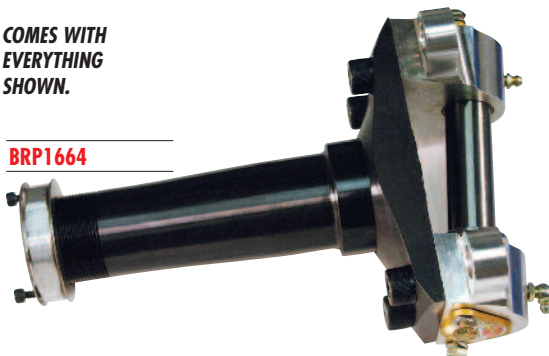

DESCRIPTION

DESCRIPTION	P/N
Spindle kit with kingpin, spacer, & locking nut	BRP1664
Hollow replacement king pin (.988")	BRP1660
King pin cap (sold each)	BRP1662
Lower spindle boss	BRP1669
Upper spindle boss	BRP1670
Spindle and plate assembly	BRP1671
Spindle bolt (4 required)	BRP1672
King pin bushing (each)	BRP1673
1/8" aluminum spindle shim spacer	BRP844
Aluminum locking spindle nut kit	BRP320
Replacement washer for BRP320	BRP320W